

专业打造中国汽保
Build the First-brand of Professional Auto Protection of China



NAN FANG

HOTON

Nanfang series--Lift

Nanfang Two Post lift NF-8540

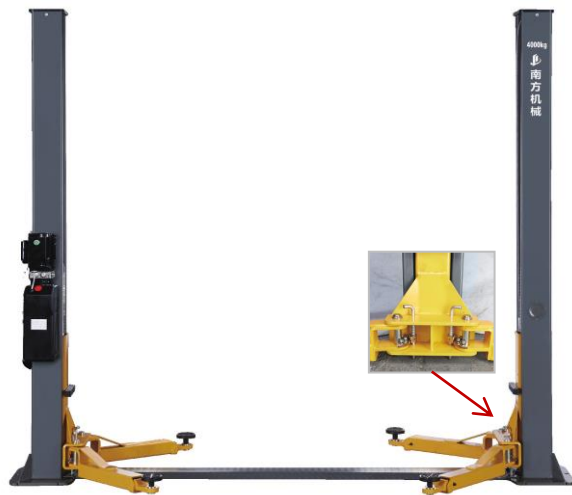

Normally , Economic,4T
 Rated load: 4000kg
 Lifting height: 1900mm
 Initial height: 110mm
 Lifting time: 50s
 Lowering time: 20s
 Passing width: 2506mm
 Overall width: 3380mm
 Overall height: 2891mm
 Motor power : 2.2kw
 Motor voltage: 3 phase/380v or Single phase/220V
 Working noise: 75dB (A)
 Working oil pressure: 18M Pa
 package:285x55x68cm weight:550kg

Nanfang Two Post lift NF-8840



4T,Three joint arm, Double side manual release
 Rated load: 4000kg
 Lifting height: 1900mm
 Initial height: 35-120mm
 Lifting time: 50s
 Lowering time: 20s
 Passing width: 2506mm
 Overall width: 3410mm
 Overall height: 2891mm
 Motor power : 2.2kw
 Motor voltage: 3 phase/380v or Single phase/220V
 package:285x55x68cm weight:560kg

Nanfang Two Post lift(single release) NF-8640



4T, Single side manual release, Economic
 Rated load: 4000kg
 Lifting height: 1880mm
 Initial height: 35-100mm
 Lifting time: 50s
 Lowering time: 20s
 Passing width: 2486mm
 Overall width: 3338mm
 Overall height: 3700mm
 Arm length: 800mm~1130mm
 Motor power : 2.2kw
 Motor voltage: 3 phase/380v or Single phase/220V
 package:370x55x68cm weight:630kg

Nanfang series--Lift

Nanfang Two Post lift NF-8940

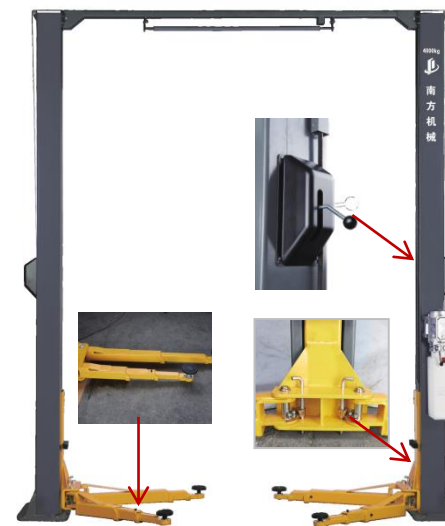

4T, Single side manual release, Three Joint Arm,high: 3891mm,680kg
 Rated load: 4000kg
 Lifting height: 1855mm
 Initial height: 35-100mm
 Lifting time: 50s
 Lowering time: 20s
 Passing width: 2490mm
 Overall width: 3417mm
 Overall height: 3700mm
 Arm length: 620mm~1090mm,910-1300mm
 Motor power : 2.2kw
 Motor voltage: 3 phase/380v or Single phase/220V
 package:370x55x68cm weight:680kg

Nanfang 4.5T Two Post lift NF-8945

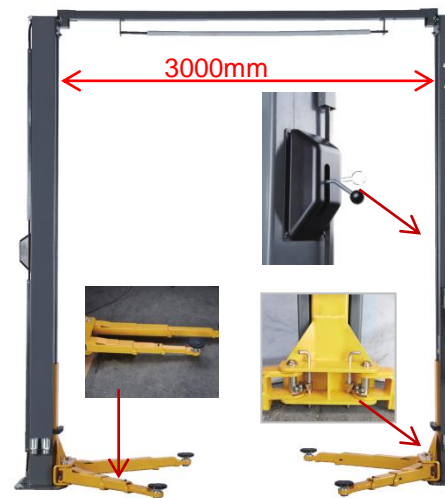

4.5T, Single side manual release, Three Joint Arm, high: 3906mm,weight:715kg, width: 3000mm
 Rated load: 4500kg
 Lifting height: 1890mm
 Initial height: 60-110mm
 Passing width: 2695mm
 Overall width: 3562mm
 Overall height: 3906mm
 Arm length: 560mm~1000mm,910-1300mm
 Motor power : 2.2kw
 Motor voltage: 3 phase/380v or Single phase/220V
 package:380x55x68cm weight:715kg

Nanfang 5.5T/6.8T Two Post lift(single) NF8655/NF8668



5.5/6.8T, Single side manual release, Three Joint Arm, high: 4450/5055mm

NF8655	Rated load: 5500kg	Rated load: 6800KG
	Lifting height: 1980mm	Lifting height: 1980mm
	Initial height: 100-130mm	Initial height: 100-130mm
	Passing width: 2910mm	Passing width: 2775mm
	Overall width: 3562mm	Overall width: 3733mm
	Overall height: 4450mm	Overall height: 5055mm
	Arm length: 910-1300mm	Arm length: 910-1300mm
	Motor power : 2.2kw	Motor power : 2.2kw
	package:380x55x68cm	package:380x55x68cm
	weight:900/980kg	weight:980kg

Nanfang series--Lift

Nanfang Four Post lift NF-9140 (No second lift)



Lift capacity: 4.0 T
 lift high: 1.66 meters
 Voltage Power: 380V 2.2 KW/220v 2.2kw
 column inner long: 4686mm
 Total long: 5746mm
 out wide: 3170mm
 pass wide: 2833mm
 height: 2035mm
 Pneumatic unlock release
 Working oil pressure: 16MPa
 Working air pressure: 0.5-0.7MPa

package:465x55x80cm weight:764kg

Nanfang Four Post lift NF-9240 (with second lifter)



Lift capacity: 4.0 T
 lift high: 1.66 meters
 Voltage Power: 380V 2.2 KW/220v 2.2kw
 column inner long: 4686mm
 Total long: 5746mm
 out wide: 3170mm
 pass wide: 2833mm
 height: 2035mm
 Pneumatic unlock release
 Working oil pressure: 16MPa
 Working air pressure: 0.5-0.7MPa

package:465x55x80cm weight:940kg

Nanfang 6.3T Four Post lift NF9465 (with second lifter)

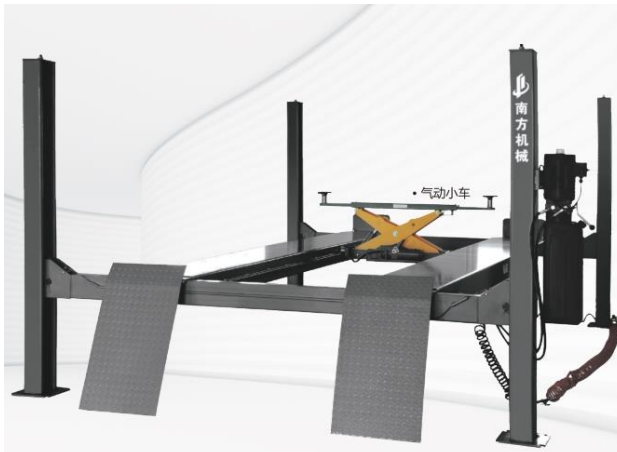

Lift capacity: 6.3 T
 lift high: 1.8 meters
 Voltage Power: 380V 3 KW/220v 3kw
 column long: 5677mm
 Total long: 6914mm
 out wide: 3440mm
 pass wide: 3000mm
 height: 2340mm
 Pneumatic unlock release
 Secondary lift Pneumatic
 Platform length: 915-1450mm
 Lifting load: 2700kg
 Lifting height: 220-450mm
 Working oil pressure: 16MPa
 Working air pressure: 0.5-0.7MPa
 package:592x55x80cm weight:1180kg

Nanfang series--Lift

Nanfang Single Scissor Lift in ground NF-6135B (3500kg)



Lift capacity: 3.5 T
 lift high: 2030 mm
 Initial height: 300mm
 Lifting time: ≤50s
 Lowering time: ≥20s
 Runway width: 550mm
 Runway length: 1530~1930mm
 Distance between two runways: 850mm
 Overall width: 2000mm
 Safety method: Mechanical safety lock pneumatic release
 Motor power : 2.2kw
 Motor voltage: 3 phase/380v or Singlephase/220V
 package:160x60x80cm weight:700kg

Nanfang Ultra-thin small scissor lift (on ground) NF-7230



Rated load: 3000kg
 Lifting height: 1750mm
 Initial height: ≤115mm
 Lifting time: ≤50s
 Lowering time: ≥20s
 Runway width: 630mm
 Runway length: 1450~2080mm
 Distance between two runways: 800mm
 Overall width: 2040mm
 Safety method: Mechanical safety lock pneumatic release
 Motor power : 2.2kw
 Motor voltage: 3 phase/380v or Singlephase/220V

package:160x70x40cm weight:750kg

Nanfang Double Scissor lift (In ground) NF-8242



Three tooth Extend Small box

Rated load: 4200kg
 Lifting height: 1810mm|
 Secondary lifting height: 450mm|
 Initial height: 330mm
 Lifting time: ≤60
 Secondary lifting time: ≤30s
 Lowering time: ≥20s
 Secondary lowering time: ≥12s
 Runway width : 600mm
 Runway width: 4500mm
 Secondary runway width: 1450mm
 Side slip plate length :1600mm
 Advised distance between runways: 940mm
 Overall width: 2160mm
 Safety method: Mechanical lock +pneumatic release
 Motor voltage: 3 phase/380v or Single phase/220V 3kw
 package:450x62x68cm weight:1900kg

Nanfang series--Lift

Nanfang Supper thin Double Scissor lift(on ground) NF-8335



Rated load: 3500kg
 Lifting height: 1745mm|
 Secondary lifting height: 400mm|
 Initial height: 205mm
 Lifting time: ≤60
 Runway width : 600mm
 Runway width: 4500mm
 Secondary runway width: 1450mm
 Side slip plate length :1600mm
 Advised distance between runways: 850mm
 Overall width: 2160mm
 Safety method: Mechanical lock
 Motor voltage: 380v/220V 3kw



205mm



Extend

Package:450x68x38cm Weight:2100kg

Nanfang New Energy Battery Lift NF-2110



Lift capacity: 1.2T
 lift high: 1.1-1.8 meters
 Pneumatic: 0.6-0.8MPA
 Total long: 1250mm
 out wide: 800mm
 hieght: 1100-1800mm
 Pneumatic unlock release
 Working oil pressure: 16MPa
 Working air pressure: 0.5-0.7MPA

package140x90x120cm weight:360kg

Nanfang New Energy Battery Lift NF-1210



Lift capacity: 1.0T
 lift high: 0.5-1.8 meters
 Total long: 1500mm
 out wide: 800mm
 hieght: 500-1800mm
 voltage:220v

package150x90x120cm weight:360kg

Nanfang series--Lift

Nanfang Carrier Platform NF-1212



Lift capacity: 1.2T
 Platform surface:1200*700mm
 hieght: 400-1750mm

package140x90x120cm weight:218kg

Nanfang Carrier Platform NF-1280



Lift capacity: 0.8T
 Platform surface:1200*600mm
 hieght: 400-1750mm

package140x90x120cm weight:168kg

Nanfang Carrier Platform NF-1250



Lift capacity: 0.5T
 Platform surface:920*500mm

hieght: 370-1550mm

package140x90x120cm weight:130kg

Nanfang series--Lift

Nanfang 3D Four wheel aligner NF-9000



23.6Inch LCD, Fixed camera, Same target, 100-240v

Calibration? No need.
Accurate measurement result, High repeatability.
Display accuracy: Range -, Accuracy $1/0.01^\circ / 0.1\text{mm}$
Camber: Range $\pm 8^\circ$, Accuracy $\pm 2'$
Caster: Range $\pm 19^\circ$, Accuracy $\pm 5'$
K.P.I.: Range $\pm 19^\circ$, Accuracy $\pm 5'$
Toe-in: Range $\pm 19^\circ$, Accuracy $\pm 2'$
Set back: Range $\pm 5^\circ$, Accuracy $\pm 2'$
Thrust angle: Range $\pm 5^\circ$, Accuracy $\pm 2'$
Thread: Range 2,000mm, Accuracy $\pm 2\text{mm}$
Wheelbase: Range 4,000mm, Accuracy $\pm 2\text{mm}$
package: 1290cm \times 42cm \times 40cm / 120cm \times 62cm \times 110cm weight: 180kg

Nanfang Tire Changer NF-5024



11-26", cheaper

Pneumatically operated tilting column
Simultaneous pneumatic horizontal and vertical arm locking
Capable of handling stiff, wide and low-profile tire
Right help arm
Motor power 1.1kw Power supply 220V
Max. wheel diameter 40"(960mm)
Max. wheel width 14"(355mm)
Outside clamping 11"~24"
Inside clamping 13"~26"
Carton Size 100*970*770(main body)
1230*450*350mm(help arm)
Weight 340/380kg

Nanfang Tire Changer NF-5026



11-26", Auto Hook

Pneumatically operated tilting column
Simultaneous pneumatic horizontal and vertical arm locking, auto hook
Capable of handling stiff, wide and low-profile tire
Right help arm
Motor power 1.1kw Power supply 220V
Max. wheel diameter 40"(960mm)
Max. wheel width 14"(355mm)
Outside clamping 11"~24"
Inside clamping 13"~26"
Carton Size 100*970*770(main body)
1230*450*350mm(help arm)
Weight 392/432kg

HOTON

Nanfang series--Lift

Nanfang Wheel Balancer NF3023



For passenger car, motorcycle and light commercial vehicle wheels
Hand-operated distance and wheel diameter input
Various balancing modes
Self-calibration and diagnosis
Optional plastic safe-guard, universal wheel flange, motorcycle adaptor and large centring cone
Max. wheel weight 65kg
Motor power 0.2kw/0.37kw 220V
Balancing accuracy $\pm 1\text{g}$
Rim diameter 10"~24"
Rim Width 1.5"~20"
Package size 960*760*1230mm Weight 95/126kg

Nanfang Wheel Balancer NF3028



Aluminium gauge head with wheel weight clamp
Automatic distance and wheel diameter measuring
Pluggable position pick up board SP and hidden weight mode OPT mode for optimization
Self diagnoses, easy to find the problem
Max. wheel weight 65kg
Motor power 0.2kw/0.37kw, 220V
Balancing accuracy $\pm 1\text{g}$
Rim diameter 10"~24"
Rim Width 1.5"~20"
Package size 960*760*1230mm
Weight 95/126kg

Nanfang 3D Automatical wheel balancer NF3038



1. automatically to improve the precision and reduce measurement time
2. Automatic measure three parameters distance ("a" value), rim diameter ("d" value) and rim width
3. Laser positioning of adhesive weights
4. Fully automatic positioning at the unbalance point on both inside and outside of the rim with laser indication

Rim Diameter Range: 10~30"
Rim Width Range: 1.5~22"
Max. Wheel Diameter: 1080mm
Working Pressure: 0.8~1MPa
Max. Wheel Weight $\leq 80\text{kg}$

P5

Nanfang series--Lift

Nanfang

Engine decarbonizer carbon cleaner NF-6010



Carbon Cleaning , an innovative solution to keep your engine clean

1. Without engine dismantling, simple operation only takes 20-40 minutes, save time and labor cost.
2. Completely removes carbon without damaging engine.
3. Eco friendly, no second pollution
4. Low cost, only has pure water consumption.
5. Suitable for all diesel and gasoline engines.

Voltage 220V
 Rated power 1.2kw
 Dimensions (L*W*H) 670×560×940mm
 Weight 35kg
 Working pressure 0.6-0.8Mpa

Nanfang

Dry ice blasting machine dry ice blaster NF6012



Voltage: AC220V, 50 ~ 60Hz (handle, 24V)
 Air supply pressure: 6-8kg
 air supply flow: 1 -2.0m³/ Min
 dry ice injection volume: 0.1 - 0.4kg/min
 dry ice capacity: 20kg
 machine size: 462 * 400 * 800mm

Nanfang

Dust-free dry miller



Dust free dry mill
 Maximum power of motor: 1200W
 Maximum flow: 3900L / min
 Maximum vacuum: 2400pa
 Filtering area: 6236 square
 Overall size: 50 *50*134cm

package:134*50*50cm weight:36kg

The original European motor
 Two mills and work at the same time,
 Different from other modified household vacuum cleaners
 dust suction pipeline and quick connector

Nanfang series--Lift

Nanfang

Scroll air compressor NF-7508



Exhaust pressure: 0.8MPa
 Voltage: 380V
 Motor power: 7.5kw 10HP
 Volume flow: 1.1m³/ min
 Weight: 185kg
 Package size: 900x560x780mm
 Control drive mode: fully automatic direct connection

Nanfang

Scroll air compressor NF-7510



Exhaust pressure: 1.0MPa
 Voltage: 380V
 Motor power: 7.5kw 10HP
 Volume flow: 1.0m³/ min
 Weight: 185kg
 Package size: 900x560x780mm
 Control drive mode: fully automatic direct connection

Nanfang

220V Scroll air compressor (with 220L tank) NF-2210



Exhaust pressure: 1.0MPa
 Voltage: 220v
 Motor power: 2.2kW 3HP
 Volume flow: 0.3m³/ min
 Weight: 150kg
 Package size: 750x450x1290mm
 Control drive mode: fully automatic direct connection
 Tank:220L

Nanfang series--Lift

Bearing capacity: 3T
working range: 127-464mm
Package: 750x360x200mm
Gross/net : 34/32kg



Bearing capacity: 3T
working range: 75-505mm
Package: 800x360x200mm
Gross/net : 36/34kg



Nanfang

KYQ3 3T TWIN Pump fast floor Jack

Nanfang

KYDL3 3T TWIN Pump fast floor Jack

Capacity: 3T
working range: 68-600mm
Package: 905x364x155mm
Gross/net : 46/44kg
length:883mm



KCD3 3T Twin Pump long floor Jack

Capacity: 5T
working range: 155-585mm
Package: 1530x430x330mm
Gross/net : 120/100kg
length:1300mm



LYC5 5T Heavyduty floor Jack

Capacity: 10T
working range: 170-5700mm
Package: 1660x530x360mm
Gross/net : 170/150kg
length:1400mm



LYC10 10T Heavyduty floor Jack

Capacity: 20t
Piston rod stroke: 135mm
Package size: 1540x290x160mm
Gross / net weight (kg): 95 / 87kg



NF2020 Shop press

capacity: 30T
Piston rod stroke: 130mm
Package size: 1850x800x280mm
Gross / net weight (kg): 150 / 137kg



NF2030 Shop press

capacity: 50t
Stroke: 220mm
Package size: 1800x940x400mm
Gross / net weight (kg): 246 / 222kg



NF2050 Shop press

Maximum load: 0.5T
Piston rod stroke: 870-1800mm
Package size: 900x365x50mm
Gross / net weight: 101 / 88kg



LYJ05 Transfer carrier

Maximum load: 0.5T
Piston rod stroke: 850-1770mm
Package size: 800x540x230mm
Gross / net weight: 51 / 44kg



NF2006 transfer carrier

Maximum load: 0.5T
Package size: 1840x200x85mm
Gross / net weight: 16.5/15.5kg

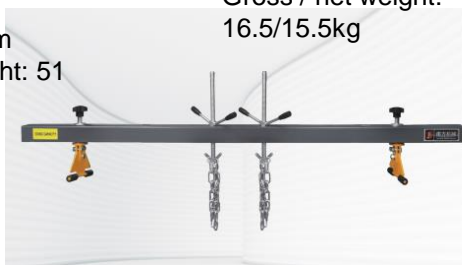

NF2004 engine crane

Nanfang series--Lift



Maximum load: 2T
Piston rod stroke: 0mm-2300mm
Package size: A: 1410x310x200mm
B: 860x580x90mm
Gross / net weight: 85 / 75kg

NF2001 2T Engine crane



capacity: 500kg
Column: 150 * 150 * 5mm
Size: 930 * 610 * 680mm
Oil basin size: 660 * 500

NF2250:0.5T ENGINE Frame



capacity: 1T
Spring range: 102-254mm
Working range: 325mm
Package size: 1120x280x180mm
Gross / net weight (kg): 35.5/30kg

NF9001 Spring compressor



Package size: 775x370x215mm
Gross / net weight (kg): 19.6/19kg

NF1000 Part trolley



capacity: 10t
Lifting stroke: 150mm
Minimum height of oil cylinder: 345mm
Package size: 760x265x220mm
Gross / net weight (kg): 35 / 31kg

NF-1010N 10T portable floor Jack



Square head size: 1 / 2 inch
No load Revolution: 8500r / min
Maximum torque: 850nm
Bolt capacity: 18mm
Air inlet size: 1 / 4 inch
Air pressure: 6-8kg / cm²
Net weight: 2.5kg
Package size: 210 x ninety x 230mm

NF-2035 air wrench



Power : 220ac
accuracy: 0.05kg/cm
Display accuracy: 0.1kg/cm²
size: 200x320x70mm
Net weight 4kg

NF-1711



NF-7010



NF-7020



NF-1818



NF-1819



NF-1820



HJS0.5



HJS2



NF-0203